



DMXPEN *WTI*

Design your show, record and bring with you



cat.no. dmxpenWTIR1-UK-2010

Manual / UK

INDEX

Introduction	page	3
Warnings	page	4
SetUp / Connections	page	5
Technical Specification	page	6
Description	page	7
Touch Panel controlled DMX recording mode	page	8
Touch Panel controlled playback mode	page	9
MIDI controlled playback mode	page	9
Warranty	page	13
Maintenance / Cleaning	page	13

INTRODUCTION

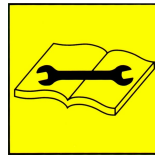

Thanks to buy this DMXPEN series products.
A correct use of this product, will ensure a correct functionality, a long life and at the same time will avoid product failure.

Please read this manual carefully and be sure to understand the information provide to ensure a safe and reliable application, to learn a suitable knowledge of the product and his necessary precaution before using it.

WARNINGS

1. This manual describes the DMXPEN WTI operating functions. The user must operate the product according to the performance specifications described in the operation manuals.
2. While every effort has been made to ensure that the information on this manual is accurate and complete, we would appreciate any errors or omissions submitted to our attention.
3. Maintenance, inspection, and replacement of parts must be performed only by authorized personnel.
4. We reserve the right to change the specifications of the hardware and software described in this manuals at any time and without prior notice.
5. Do not use DMXPEN WTI with wet finger and do not place water on the touch panel.
6. After the package opening, please make this check:
 - The received product correspond with the ordered one.
 - No part are missing on the received product.
 - The product is not damaged.
 - Contact immediately a DMXPen distributor in case of fault.

SET UP/CONNECTION

DMXPEN WTI was developed for a embedded wall mount installation on BTCino o similar 503 box.

We suggest to embed for 2-3mm the 503 box respect the wall surface: in this way we can have a better contact between DMXPen WTI on the wall surface.

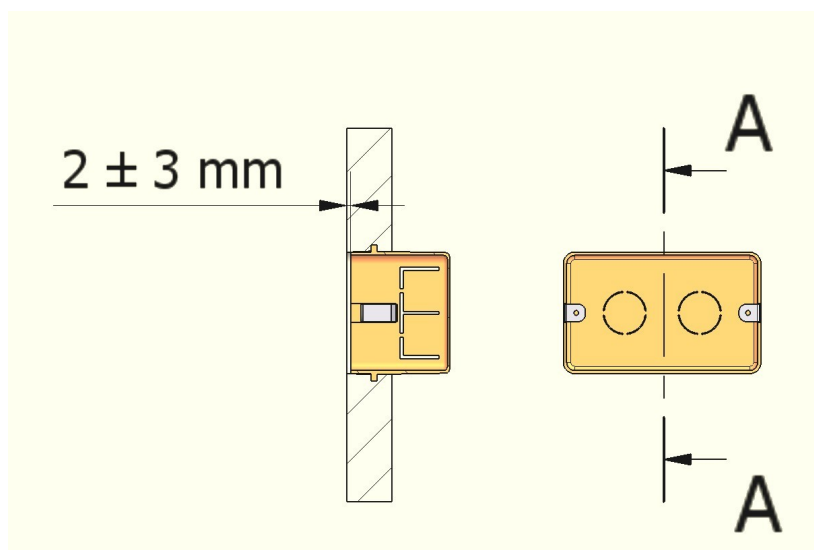

Fix the provided iron frame to 503 box.

Wire the DMX line and the 12VDC power supply on the provided removable connector (be sure that the screw up is correct). Be sure to have the microSD card inserted on the socket (the product is supplied with the microSD card inserted on the socket).

Finally, plug the removable connectors and insert DMXPen WTI on the frame having care



of the wire (be sure to not stump out any wire).

Technical Specification

Dimension (L x W x H)	134 x 36 x 99 mm
Weight	200 gr.
Material / Finishing	Plastic / Polish
One Optocoupled bidirectional DMX Line	
One DMX universe recording / playback	
One General MIDI Input port for remote control and device synchronization	
Automatic loop handling	
2GB microSD card	
Degree protection when installed to the wall	IP 40
Operating Relative Humidity : from 30% to 85% without condensation	
Operating Temperature	-5°C + 50°C
Power Supply	12-24VDC – 500 mA
Power Consumption	200 mA @ 12VDC

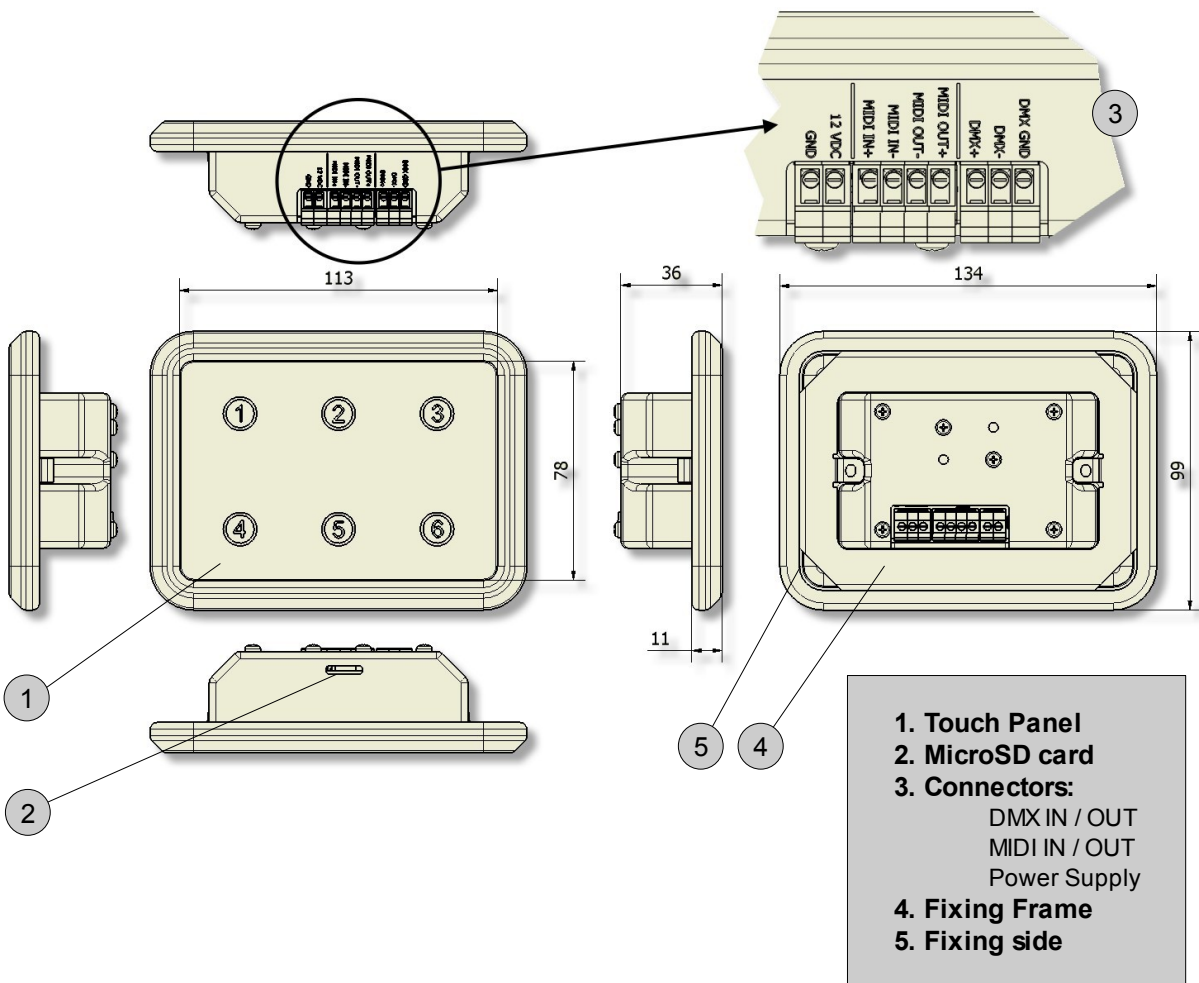

DESCRIPTION

DMXPen WTI is an embed wall mount device with the following features:

- One complete DMX512 universe recording
- One complete DMX512 universe playback
- Playback remote control through MIDI port
- Multi device synchronization through MIDI port
- Recording and Playback control through touch panel user interface

Briefly the DMXPen products mission is record and carry easily: "*Design your show, record and bring with you*".

Why recording? The first goal of a professional light programmer is to select a light desk and learn to use it in the best way, because this means freedom of expression and productivity.

The DMXPen products range improve this concept taking care of recording what the light programmer realize with his preferred equipment.

Why carry? Often the light programmer presence is not necessary during the show playback, so he can realize the show and record it so the user has only the duty to activate his playback (i.e. fair booth, shop, club, etc.)

Moreover doing this with a normal light desk, mean carry heavy or expensive equipment that usually are not so familiar to the users (i.e. barman, custodian, etc.).

This is another issue improved from the DMXPen products because contains only the show engine with a simple user interface at a very low cost.

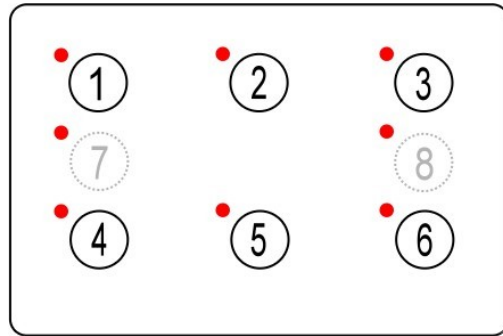

① ⑥ for each touch key 2 SHOW can be controlled

⑦ ⑧ the 7 and 8 hidden touch key, are programming key

⑦ pressing for at least 3 second the hidden touch key 7, the system go on show 1-2-3-4-5-6 recording mode:



the 1-2-3-4-5-6-7 leds blinks at slow rate in case of DMX signal not present and blinks at fast rate in case of DMX signal present.

Going in recording mode, the DMX Port is switched to Input (DMXPEN WTI has only one DMX line shared for Input and Output on the same DMX connector).

Now is possible to connect the light desk and select one of the 6 touch key associated to the primary recording session. A 10 second time out allow to exit from recording mode in case of non selection. During recording session, the led near to the associated touch key and the key 7 will blink.

Then start the show playback from the light desk. The selected touch key and key 7 will blink fast upon DMX receiving. Finally pressing any touch key ends the recording session.

During the recording session a DMX signal absence for more that 10 second, cause a recording stop operation.

⑧ pressing for at least 3 second the hidden touch key 8, the system go on show 11-12-13-14-15-16 recording mode with the same 1-6 show behavior.



The recording session are stored on the microSD card on 2 files per key:

① for key 1 the show file name are 1.bin and 11.bin

② for key 2 the show file name are 2.bin and 12.bin

③ for key 3 the show file name are 3.bin and 13.bin

etc....

in case of show file already present and DMX line present during recording session, the show file will be overwritten.

Touch panel controlled playback mode

Note: we suggest to not hold in your hand the DMXPen WTI during recording or operation playback to avoid unintentional key press. Leave the product on the desk surface and touch the key with one finger.

On standby all led will be switched off.

Pressing the first time key 1-6, show 1.bin-6.bin (if present) will be playback on both DMX and the associated led will blink 2 times in a short time with a long off time.

In case of show not present, the led associated to the relative key will blink slowly 2 timers and after 2 second the device back to standby state.

During playback, the show runs an automatically loop mode.

Pressing the second time key 1-6, show 11.bin-16.bin (if present) will be playback and the associated led will blink 1 times with a long off time.

Each time the key number will be changed, the show selection restart from show 1-6 in the first pressure and 11-16 in the second pressure.

MIDI Remote control playback mode

The MicroSD card recorded session can be playback also through the MIDI port using a normal MIDI device as a guitar MIDI foot switch, MIDI keyboard, or other MIDI device.

The DMXPen products are arranged to receive *Program Change* MIDI command, used in most case from MIDI device to recall a preset

A preset 1 recall will start show playback 1, preset 2 recall will start show playback 2, and so on.



DMXPen WTI allow also to synchronize more than one WTI device as well as sound and light devices.

Assuming that the two DMXPen WTI are wired as explained in the figure below, pressing the first DMXPen WTI touch key 1, the playback of show n. 1 is started as well as the "Program Change" 1 is sent on MIDI OUT port. At the same time the "Program Change" 1 command is received from the second DMXPen WTI through the MIDI IN port that starts show n.1 playback.

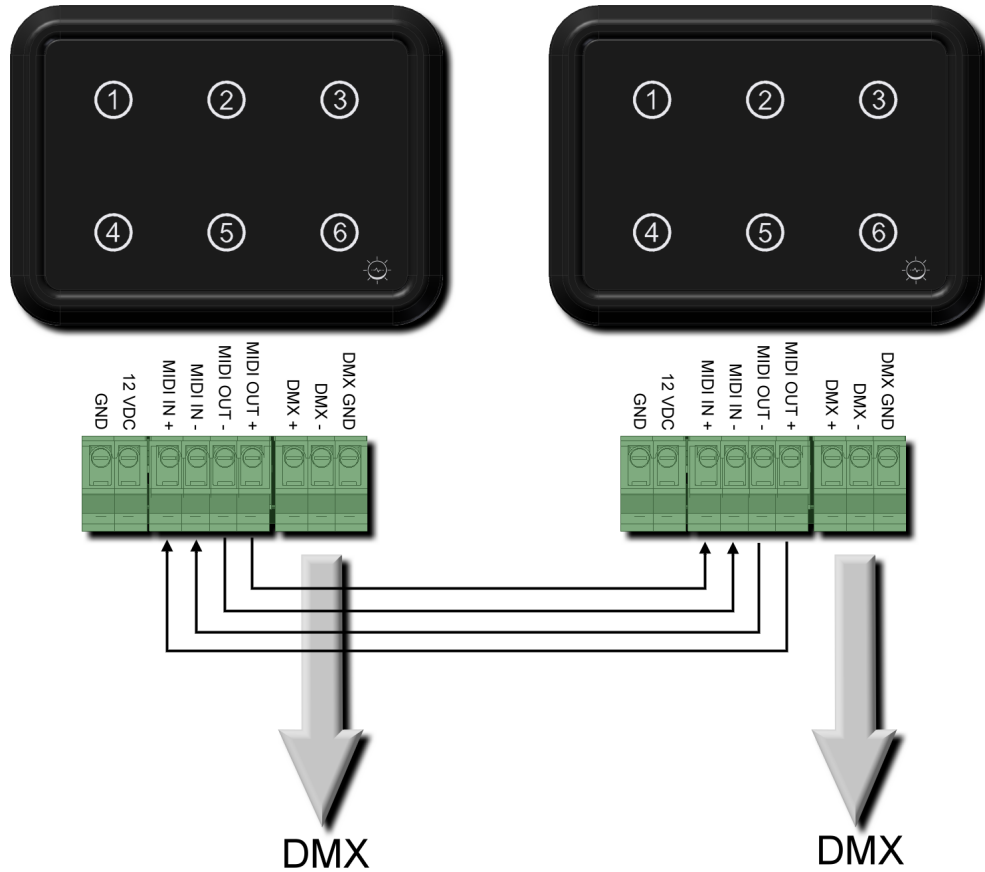

Figure 1: Universe Multiplying / Buffering / BackUp

Remember that on the MIDI Line only the playback request will be sent, not the show content.

On the DMX Output line of each DMXPen WTI the show stored on relative microSD card will be playback. This configuration allow us to accomplish the following features:

1. **DMX Universe Multiplying:** the show playback will be synchronized on all the DMXPen WTI linked together, so if the DMX channel required exceed the universe (greater than 512) we can divide the DMX line in more than one DMX line that will be connected to each DMXPen WTI. On each DMXPen WTI the show concerned to the connected DMX line will be recorded. In this way pressing the touch key associated to the show all the WTI linked playback will be started, each one generating it's own line show that will appear as a unique show to the audience.

2. *DMX Line Buffering/BackUp Line:* If the DMX channel amount is less or equal to one universe but we need to control a high number of fixture, we can record the same shows on all DMXPen WTI (we can copy also the .BIN file using a PC and a card reader) that will be playback simultaneously pressing any of the touch key. The same happen if we need a backup line of the show.
3. *Distributed Remote Control:* If the user need to start show playback from different physical point, we can use the DMX line output of one DMXPen WTI and link the other WTI through the MIDI line. To have the same LED operation we suggest to have the same show number present on all the microSD card (we can easily copy the same show on all the WTI device). In this way pressing the same touch key from any of the DMXPen WTI connected the same show will be playback.

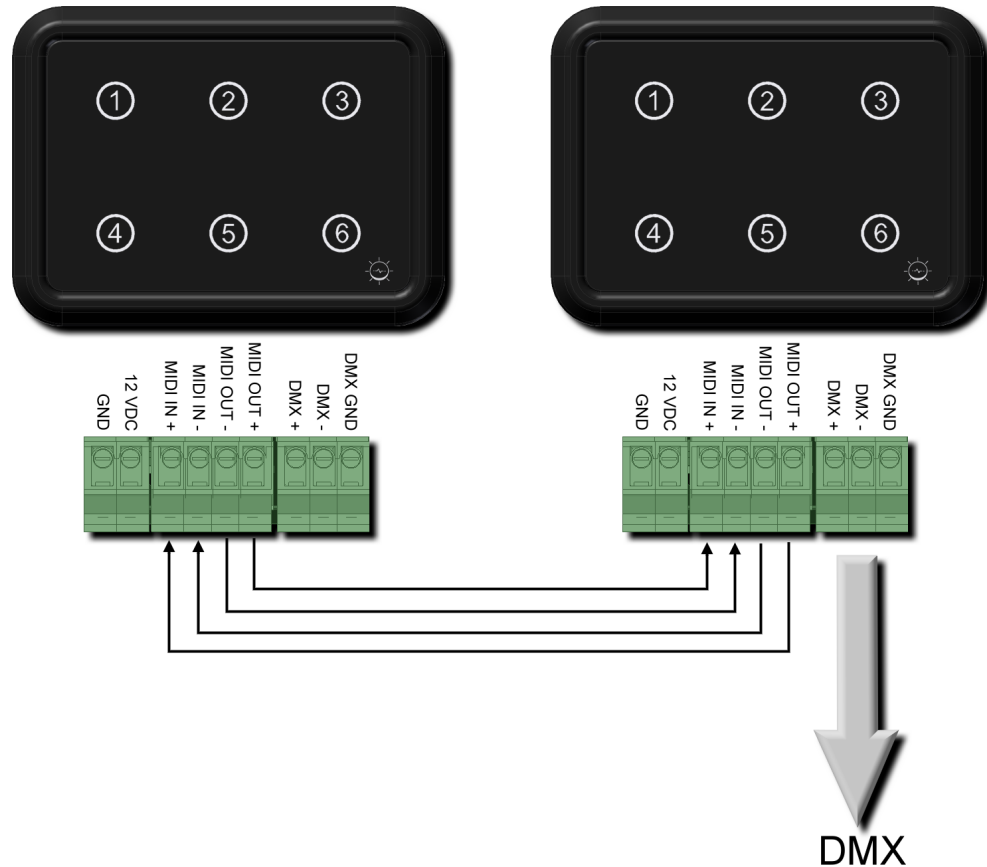

Figure 2: Distributed Remote Control

4. *Multi Priority Remote Control:* If we need to divide the DMX lines as indicated on the point 1 but we want that some DMXPen WTI can start playback for many that one device and some other only the itself shows, we can perform a unidirectional MIDI Link.

In this example we involve DMXPen WTI device only but since the link signal is a standard General MIDI communication protocol, we can extend this features involving any device provided with the General MIDI communication protocol.

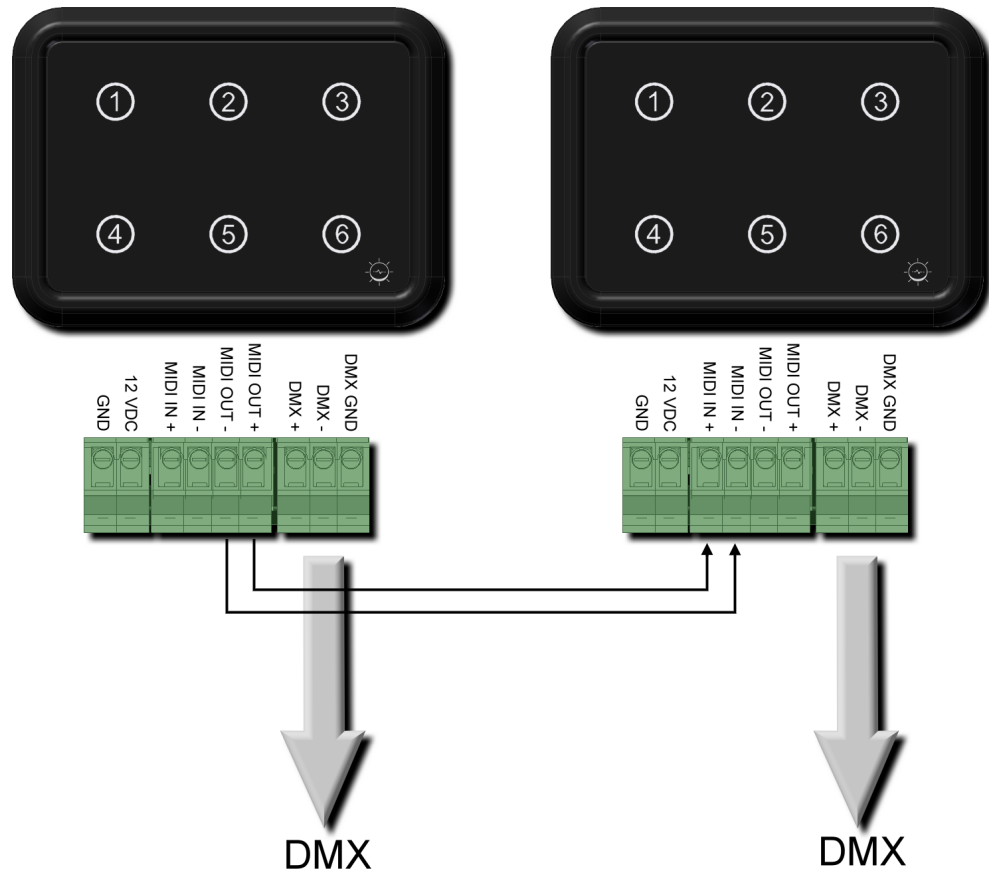

Figure 3: Multi Priority Remote Control

WARRANTY

12 month

(according to D.L. n.24 2 february2002, directive 1999/44/CE of European Parliament)

MAINTENANCE / CLEANING

No special maintenance operation are required for DMXPEN WTI.

Anyway remember to unplug the device from the power supply during maintenance and cleaning operation.

Moreover we suggest to make a backup copy of the show file stored on the microSD card using a PC connected or other card reader device.

Use only humid cleaning cloth to clean DMXPen WTI. Do not use cleaning solvent or washing powder.

www.dmxpen.com



DMXPEN

Design your show, record and bring with you



www.esta.org



www.ArtisticLicence.com
*Designed by and Copyright
Artistic Licence (UK) Ltd.*